

P-38

Revision 1

Page 2

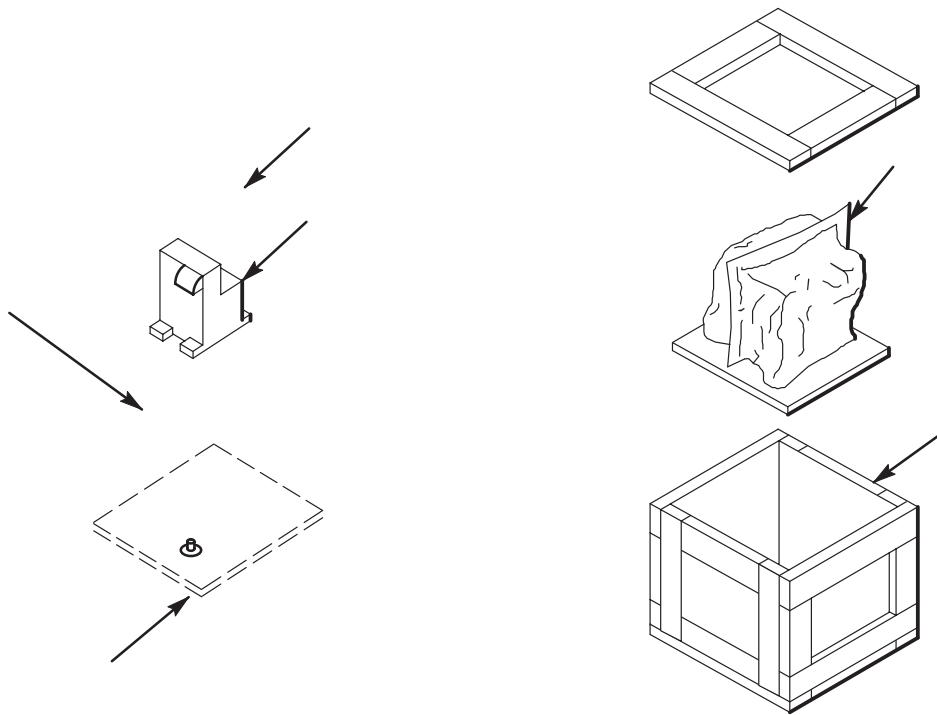

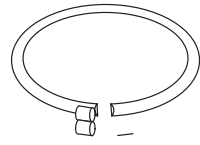

Table 1 CUSHIONING		
LPS Suffix	Type of Material	Material Specification
A	Cellulosic Material	PPP-C-843
B	Cellulosic Material – Tubular Free Flow	MIL-C-23734
C	Cellular Plastic (Flexible) 3/16” Cells	MIL-C-81013
D	Cellular Plastic (Flexible) 1/2” Cells	MIL-C-81013
E	Bound Fiber – Type I, Class B, Soft	PPP-C-1120
F	Bound Fiber – Type II, Medium Soft	PPP-C-1120
G	Bound Fiber – Type III, Medium Firm	PPP-C-1120

Table 2 CUSHIONING THICKNESS	
LPS Suffix	Cushioning Thickness Required on All Sides of the Item*
A	1/2"
B	1"
C	2"
D	3"
E	4"
F	5"
G	6"
X	As Required

*For Type 2 packaging, cushioning material may be placed between the inner and outer container. The item must be properly blocked/braced in the inner container to prevent damage to the item/container.